

**Design No. D925**

Restrained Assembly Ratings — 3/4, 1, 1-1/2, 2 or 3 Hr (See Items 1, 6 and 10)  
 Unrestrained Assembly Rating — 0 Hr (See Items 3, 4, 4A and 10)  
 Unrestrained Beam Ratings — 1, 1-1/2, 2, 3 and 4 Hr (See Items 4, 4A and 10)  
 Restricted Load Condition — See Supports and Item 4C  
 Load Restricted for Canadian Applications — See Guide BXUV7

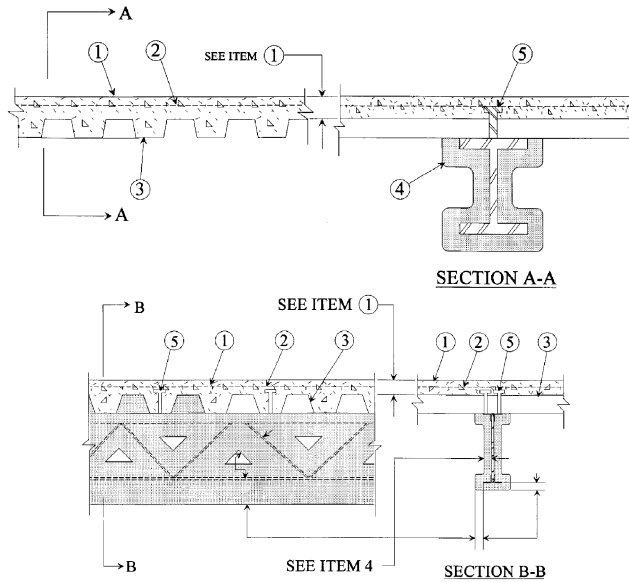

**Supports** — W8x28, W12x16 or alternate (per Section IV.6 in the front of the Fire Resistance Directory) steel beam or min 8K1 steel joists when joist substitution applied.

- Normal Weight or Lightweight Concrete** — Normal weight concrete carbonate or siliceous aggregate, 3500 psi compressive strength, vibrated. Lightweight concrete, expanded shale, or slate aggregate by rotary-kiln method, or expanded clay aggregate by rotary-kiln or sintered-grate method, 3000 psi compressive strength, vibrated, 4 to 7 percent entrained air.

Restrained Assembly Rating Hr	Concrete (Type)	Concrete Unit Weight pcf	Concrete Thkns In.
1	Normal Weight	147-153	3-1/2
1-1/2	Normal Weight	147-153	4
2	Normal Weight	147-153	4-1/2
3	Normal Weight	147-153	5-1/4
3/4 or 1	Lightweight	107-113	2-1/2
1	Lightweight	107-120	2-5/8
1-1/2	Lightweight	107-113	3
2	Lightweight	107-113	3-1/4
2	Lightweight	107-116	3-1/4*
2	Lightweight	114-120	3-1/2
3	Lightweight	107-113	4-3/16
3	Lightweight	114-120	4-7/16

\*For use with 2 or 3 in. steel floor and form units only.

- Welded Wire Fabric** — 6 x 6, 10 x 10 SWG.
  - Negative Reinforcement** — (Not Shown) - Optional - For 3/4, 1, 1-1/2 and 2 Hr Restrained Assembly Rating Only. Used in lieu of Item 2 and with Item 2B. For floor spans with concrete cast continuous over the supporting beams. Deformed bars designed to resist the support moments of the concrete slab in accordance with the latest ACI Building Code Specifications.
  - Fiber Reinforcement\*** — (Not Shown) - For 3/4, 1, 1-1/2 and 2 Hr Restrained Assembly Rating Only. Required with Item 2A. Engineered synthetic fibers added to concrete mix to control shrinkage cracks in concrete. Fibers added to concrete mix at rate of 5 lbs of fiber for each cubic yard of concrete.
- W R GRACE & CO - CONN** — Type Strux 90/40.
- Steel Floor and Form Units\*** — Composite 1-1/2, 1-5/8, 2 or 3 in. deep galv units or 4-1/2 in. deep noncomposite galv units. Fluted units may be uncoated or phosphatized/painted. Min gauges are 22 MSG for fluted and 20/20 MSG for cellular units. The following combinations of units may be used:
    - All 18, 24, 26 28 or 36 in. wide cellular.
    - All fluted.
    - One or two 3 in. deep, 12 in. wide, 18/18 MSG min cellular units, alternating with 3 in. deep fluted or other cellular.
    - Any blend of fluted and 18, 24, 26, 28, or 36 in. wide cellular.
    - 3 in. deep, 30 in. wide cellular with 8-1/8 in. wide valley alongside joints may be used when 3/8 in. diam reinforcing bars are placed 1-1/2 in. to each side of side joints and 1 in. above bottom of units.
    - Corrugated, 1-5/16 in. deep, 30 in. wide, 24 MSG min galv units with shear wires factory welded to deck corrugations. Welded to supports 12 in. OC. through welding washers. For shear wire spacing of 8 in. or less the steel deck stress shall not exceed 20 KSI. For shear wire spacing greater than 8 in. OC. but less than or equal to 12 in. OC. steel deck stress shall not exceed 12 KSI.

**ASC STEEL DECK, DIV OF ASC PROFILES L**

**L C** — 24, 30, or 36 in. wide, Types B Hi-Form, BF Hi-Form, N Hi-Form, NF Hi-Form, 2W Hi-Form, 2WF Hi-Form, 3W Hi-Form, 3WF Hi-Form, BR Hi-Form, BMOD Hi-Form, BRMOD Hi-Form, DGB Hi-Form, DGBF Hi-Form, DGN Hi-Form, DGN32 Hi-Form, DGNF Hi-Form, DGNF32 Hi-Form, DG2W Hi-Form, DG2WF Hi-Form, DG3W Hi-Form, and DG3WF Hi-Form; 32 in. wide Type N-32, NF32, DGN32, DGNF32; 24 or 30 in. wide Types ASC2 or ASC3. All units may be galvanized or Prime Shield.

**CANAM STEEL CORP** — 36 in. wide Type P-3623, P-3606, P-3615 and 24 in wide Type P-2432 composite.

**CANAM STEEL CORP** — 24 in. wide, Types 1-1/2, 2 or 3 in. LOK-Floor and LOK-Floor Cell; 36 in. wide, Types 2 or 3 in.

LOK-Floor and LOK-Floor Cells; 24 in. wide, Types N-LOK and N-LOK Cell; 24, 30 or 36 in. wide, Type 1-1/2 in. B-LOK and B-LOK Cell.

**CONSOLIDATED SYSTEMS INC** —24 in. wide Types CFD-2, CFD-3; 24, 30 or 36 in. wide Type CFD-1.5; 24 or 36 in. wide Types Mac-Lok 2, Mac-Lok 3; 24 in. wide, Types B2C, B2FC, NC, NFC; 30 in. wide Type B3C; 12 in. wide Mac-Way cellular 45 MOW, 2-633 MTWA, 3-633 MTWA, 3-633 MTWV, 3-633 MTWV+, 24 in. wide Type Versa-Dek.

**DECK WEST INC** — 36 in. wide Type B-DW, 2-DW or 3-DW. Side joints of 2-DW and 3-DW may be fastened together with min 1 in. long No. 12 x 14 self-drilling, self-tapping steel screw 36 in. OC.

**DESIGN ASSISTANCE CONSTRUCTION**

**SYSTEMS INC** —36 in. wide Type DACS1.5CD, or 24 in. wide Type DACS2.0CD, or DACS3.0CD.

**EPIC METALS CORP** —24 in. wide Types EC150, ECP150, EC300, ECP300, EC366, ECP366, EC150, EC300 inverted, Epicore A; 30 in. wide Types ECB150, ECBR150; 36 in. wide Types EC266.

**H H ROBERTSON** —QL Types, 24 in. wide 3 or 3 inverted, UKX, UKX-3, 2 in. 99, AKX, 21 or 21 inverted, 121, NKX, TKX; 24 or 30 in. wide GKX, GKX-A; 36 in. wide 99, AKX, WKX; 24, 26, 94, 36 in. wide NKX; 1.5NKC, NKC, AKX, 2 or 3 in. TKC; 12 in. wide noncomposite Sec. 12; 17 in. wide 21; 26 or 28 in. wide UKX, 87.5 cm wide. Side joints of QL, 99, 121, WKX, TKX, TKC, and Metric units — QL-77-900; QLC-78-900; may be welded together 60 in. OC. Side joints of 99, AKX, WKX, GKX, GKX-A, TKX and Metric units — QL-77-900 and QLC-78-900 may be fastened together with min 1 in. long No. 12x14 self-drilling, self-tapping steel screws 36 in. OC.

**HAMBRO STRUCTURAL SYSTEMS, DIV OF**

**CANAM STEEL CORP** —36 in. wide, 1-1/2 in. Type P3615HB. The max superimposed loadings for Type P3615HB units shall not exceed 250 PSF. For single spans, the use of the units shall be limited to 5 ft. 6 in., 6 ft 0 in. and 6 ft 6 in. max spans for the 22, 20 and 18 gauge units, respectively. For multiple spans, 18 gauge units may be used on a max 7 ft 6 in. span with a max total superimposed loading of 240 PSF.

**KAM INDUSTRIES LTD, DBA CORDECK** —24 in. wide Types 2 or 3 in. WDR.

**MARLYN STEEL DECKS INC** —Type 1.5 CF, 2.0 CF or 3.0 CF.

**NEW MILLENNIUM BUILDING SYSTEMS L L C** — Type 1.5CD, 1.5CDI, 1.5CDR, 2.0CD or 3.0CD. Units may be phos/painted or galvanized.

**VALLEY JOIST** —24 or 36 in. wide Types WVC 1-1/2 or WVC 2.

**VERCO DECKING INC - A NUCOR CO** —24, 30 or 36 in. wide Types PLB, PLBCD, B, BCD, BR; 24 or 36 in. wide Types PLW2, PLW2CD, W2, W2CD, PLW3, PLW3CD, W3, W3CD; 24 in. wide Types PLN, PLNCD, N, NCD. 12 in. wide PLW2, W2, PLW3 or W3 units may be blended with 24 or 36 in. wide PLW2, W2, PLW3 or W3 units, respectively; or Types N3, PLN3, N3-CD, PLN3-CD. Fluted units may be phos/ptd.

**VULCRAFT, DIV OF NUCOR CORP** —24, 30 or 36 in. wide, Type 1.5 VL, 1.5 VLI, 1.5 VLP; 24 or 36 in. wide. Types 2VLI, 2VLP, 3VLI, 3 VLP. 36 in. wide Types 1.5 SB, 1.5 SBR; 24 or 36 in wide Types 2.0 SB, 3.0 SB, 36 in. wide Type High Strength 1.5 SBI, 36 in. wide Type High Strength 1.5 SBN.

Components for field-assembled cellular metal raceway units:

**Raceway Bottom** — 24 or 36 in. wide Types 212 VS, 312 VS .

**Raceway Cover Plate** — Types CP-12, CP-16.

**Raceway Divider** — Type DC-20, DC-25.

**Racway Isolation Trough** — Types T-20, T-25, T-30.

Spacing of welds attaching units to supports shall be 12 in. OC for 12, 24 and 36 in. wide units, four welds per sheet for 30 in. wide units, 6 in. OC for 18 in. wide and Sec. 12 units. Unless noted otherwise, adjacent units button-punched or welded together 36 in. OC alongside joints. Adjacent 18 in. wide units welded together 30 in. OC alongside joints. For 3 Hr Rating, units with overlapping type side joints welded together 24 in. OC max.

**The Unrestrained Assembly Rating is equal to the Unrestrained Beam Rating for a max of 3 Hr and is limited to the following floor units and spans:**

- (a) 1-1/2, 2 and 3 in. deep, 24 in. wide, 22 MSG or thicker fluted with clear spans not more than 7 ft, 8 in.
- (b) 1-1/2, 2 and 3 in. deep, 24 in. wide, 20 MSG or thicker fluted with clear spans not more than 8 ft, 8 in.
- (c) 1-1/2 and 2 in. deep, 24 in. wide, 16 MSG or thicker fluted and 18/18 MSG or thicker cellular with clear spans not more than 9 ft, 11 in.
- (d) 3 in. deep, 36 in. wide, 18 MSG or thicker fluted and 24 in. wide, 20/18 MSG or thicker cellular with clear spans not more than 13 ft, 2 in.

For assemblies utilizing 3-1/4 in. lightweight concrete topping with a max Restrained Assembly Rating of 2 Hr, the Unrestrained Assembly Rating is equal to the Unrestrained Beam Rating and is limited to the following floor units and spans:

- (a) 1-1/2, 2, and 3 in. deep, 24 or 36 in. wide, 22 MSG fluted and 20/20 MSG cellular with clear spans not more than 9 ft, 6 in.
- (b) 2 and 3 in. deep, 24 or 36 in. wide 20 MSG fluted and 20/20 MSG cellular with clear spans not more than 10 ft, 0 in.
- (c) 3 in. deep, 24 in. wide, 20 MSG fluted and 20/20 MSG cellular with clear spans not more than 13 ft, 2 in.

4. **Spray-Applied Fire Resistive Materials** — Applied by mixing with water and spraying in one or more coats to a final thickness as shown in the tables below, to steel beam surfaces which must be clean and free of dirt, loose scale and oil. Min avg and min ind density of 15/14 pcf, respectively for Types MK-6/HY, MK-6/HY Extended Set, MK-6/HB, MK-6s, MK-6 GF, MK-6 GF Extended Set, MK-10 HB, MK-10 HB Extended Set, MK-1000/HB, MK-1000/HB Extended Set, RG. Min avg and min ind density of 22/19, respectively for Types Z-106, Z-106/G. For method of density determination, refer to Design Information Section.

Restrained Assembly Rating Hr	Unrestrained Assembly Rating Hr	Unrestrained Beam Rating Hr	W8x28 Beam (see Note #1)	W8x28 Beam Supporting (see Note #1)		W12x16 Beam (see Note #1)	W12x16 Beam Supporting All Fluted Floor Unit (see Note #1)
				All Fluted Floor Units w/Light weight Concrete	Fluted Floor Units and Normal Weight Concrete Only		
1	1	1	1/2, 11/16#	5/16, 11/16#	5/16	11/16, 1-1/8#	5/8, 1#
1-1/2	1	1	1/2, 11/16#	5/16, 11/16#	5/16	11/16, 1-1/8#	5/8, 1#
1-1/2	1-1/2	1-1/2	13/16, 1-1/16#	11/16, 1#	5/8	1-1/8, 1-7/16#	1, 1-3/8#
2	1	1	1/2, 11/16#	5/16, 11/16#	5/16	11/16, 1-1/8#	5/8, 1#
2	2	2	1-1/16, 1-5/16#	1, 1-3/16#	7/8	1-7/16, 1-13/16#	1-3/8, 1-9/16#
3	1-1/2	1-1/2	13/16	11/16	5/8	1-1/8	1
3	3	3	1-9/16	1-5/16	1-7/16	2-1/8	1-3/4
3	3	4	2	1-5/8	2	2-11/16	2-3/16

Note #1: Joists from the N series designs may be substituted for the listed beam. When joists are substituted, the restrained rating of the joist must be equal to or greater than the restrained rating of the assembly. Additional joist substitution requirements are contained in the front of the Fire Resistance Directory.

#This thickness applies when optional Item 10 is used over 3-1/4 in. light weight concrete topping.

The thicknesses of Spray-Applied Fire Resistive Materials shown in the table below are applicable when the thickness applied to the beams' lower flange edges is reduced to one-half that shown in the table.

Restrained Assembly Rating Hr	Unrestrained Assembly Rating Hr	Unrestrained Beam Rating Hr	W8x28 Beam	W8x28 Beam Supporting All Fluted Floor Units w/Lightweight Concrete	W12x16 Beam	W12x16 Beam Supporting All Fluted Floor Unit
1	1	1	9/16	7/16+	3/4	5/8
1-1/2	1	1	9/16	7/16+	3/4	5/8
1-1/2	1-1/2	1-1/2	7/8	3/4	1-3/16	1
2	1	1	9/16	7/16+	3/4	5/8
2	2	2	1-3/16	1	1-5/8	1-3/8
3	1-1/2	1-1/2	7/8	3/4	1-3/16	1
3	3	3	1-3/4	1-9/16	2-3/8	2-1/8
3	3	4	2-5/16	2-1/16	3-1/8	2-3/4

+Thickness applied to beams' lower flange edges shall be a minimum of 1/4 in.

ARABIAN VERMICULITE INDUSTRIES — Types MK-6/HY, MK-6/HY Extended Set, MK-6/HB, MK-6s, MK-6 GF, MK-6 GF Extended Set, MK-10 HB, MK-10 HB Extended Set, MK-1000/HB, MK-1000/HB Extended Set, Z-106, Z-106/G.

GRACE KOREA INC —Types MK-6/HY, MK-6/HY Extended Set, MK-6/HB, MK-6s, MK-6 GF, MK-6 GF Extended Set, MK-10 HB, MK-10 HB Extended Set, MK-1000/HB, MK-1000/HB Extended Set, Z-106/G, Z-106.

W R GRACE & CO - CONN —Types MK-6/HY, MK-6/HY Extended Set, MK-6/HB, MK-6s, MK-6 GF, MK-6 GF Extended Set, MK-10 HB, MK-10 HB Extended Set, MK-1000/HB, MK-1000/HB Extended Set, RG, Z-106/G, Z-106.

4A. **Alternate Spray-Applied Fire Resistive Materials** — Applied by mixing with water and spraying in one or more coats to a final thickness as shown in the tables below to steel beam surfaces which must be clean and free of dirt, loose scale and oil. The thicknesses shown in the table below are applicable to beams supporting all fluted floor or form units. Min avg and min ind density of 22/19 pcf respectively for Z-106/HY. For density determination refer to Design Information Section.

Restrained Assembly Rating Hr	Unrestrained Assembly Rating Hr	Unrestrained Beam Rating Hr	All Fluted Floor Units w/Lightweight Concrete	W8x28 Beam Supporting (see Note #1)	Fluted Floor Units and Normal Weight Concrete Only
1	1	1	5/16, 11/16##		5/16
1-1/2	1-1/2	1-1/2	11/16, 1##		5/8
2	1	1	5/16, 11/16##		5/16
2	2	2	1, 1-3/16##		7/8
3	1-1/2	1-1/2	11/16		5/8
3	3	3	1-5/16		1-7/16
3	3	4	1-5/8		2

Note #1: Joists from the N series designs may be substituted for the listed beam. When joists are substituted, the restrained rating of the joist must be equal to or greater than the restrained rating of the assembly. Additional joist substitution requirements are contained in the front of the Fire Resistance Directory.

##This thickness applies when optional Item 10 is used over 3-1/4 in. light weight concrete topping.

ARABIAN VERMICULITE INDUSTRIES —Types Z-106/HY

W R GRACE & CO - CONN —Type Z-106/HY.

GRACE KOREA INC —Type Z-106/HY.

4B. **Alternate Spray-Applied Fire Resistive Materials** — Applied by mixing with water and spraying in one or more coats to a final thickness as shown in the tables below to steel beam surfaces which must be clean and free of dirt, loose scale and oil. The thicknesses shown in the table below are applicable to beams supporting all fluted floor or form units. Min avg and min ind density of 40/36 pcf respectively for Types AV-650, Z-146, Z-146PC and Z-146T cementitious mixture. Min avg and min ind density of 50/45 pcf respectively for Types AV800, Z-156, Z-156T and Z-156PC. For density determination refer to Design Information Section.

Restrained Assembly Rating Hr	Unrestrained Assembly Rating Hr	Unrestrained Beam Rating Hr	All Fluted Floor Units w/Lightweight Concrete	W8x28 Beam Supporting (see Note #1)	Fluted Floor Units and Normal Weight Concrete Only
1	1	1	5/16, 11/16##		5/16
1-1/2	1-1/2	1-1/2	11/16, 1##		5/8
2	1	1	5/16, 11/16##		5/16
2	2	2	1, 1-3/16##		7/8
3	1-1/2	1-1/2	11/16		5/8
3	3	3	1-5/16		1-7/16
3	3	4	1-5/8		2

Note #1: Joists from the N series designs may be substituted for the listed beam. When joists are substituted, the restrained rating of the joist must be equal to or greater than the restrained rating of the assembly. Additional joist substitution requirements are contained in the front of the Fire Resistance Directory.

##This thickness applies when optional Item 10 is used over 3-1/4 in. light weight concrete topping.

ARABIAN VERMICULITE INDUSTRIES —Types AV-650, AV-800 and Z-146 investigated for exterior use.

W R GRACE & CO - CONN —Type Z-146, Z-146T, Z146PC, Z-156, Z-156T and Z-156PC investigated for exterior use.

GRACE KOREA INC —Type Z-146 investigated for exterior use.

5. **Shear-Connector-Studs-Optional** — Studs 3/4 in. diam by 3 in. long, for 1-1/2 in. deep form units to 5-1/4 in. long for 3 in. deep form units, headed type or equivalent per AISC specifications. Welded to the top flange of the beam through the steel form units.
6. **Electrical Inserts** — (Not shown) Classified as "Outlet Boxes and Fittings Classified for Fire Resistance".

**H H ROBERTSON** —Preset Inserts.

For use with 2-1/2 in. lightweight concrete topping over QL-WKX steel floor units. Installed over factory-punched holes in floor units per accompanying installation instructions. Spacing shall not be more than one insert in each 14 sq ft of floor area with spacing along floor units not less than 48 in. OC. The holes cut in insert cover for passage of wires shall be no more than 1/8 in. larger diam than wire. Restrained Assembly Rating is 3/4 hr with Tapmate II-FS-1 and 1 hr with Tapmate II-FS-2 inserts.

**H H ROBERTSON** —Tapmate II-FS-1, II-FS-2; Series KEB.

**WIREMOLD CO** —After set Inserts. Single-service after set inserts installed per accompanying installation instructions in 2-1/2 in. diam hole core-drilled through min 3-1/4 in. thick concrete topping to top of cell of any min 3 in. deep cellular steel floor unit specified under Item 3. Spacing shall be no more than one insert in each 10 sq ft of floor area in each span with a min center to center spacing of 16 in. If the high potential and low potential raceways of the cellular steel floor unit are separated by a valley filled with concrete, the center to center spacing of the high potential and low potential single-service after set inserts may be reduced to a min of 7-1/2 in. Restrained Assembly Rating is 2 hr or less with internally protected Type 436 after set insert with Type M4-, M6- or M8- Series single-service activation fitting.

**WIREMOLD CO** — Internally protected Type 436 after set insert with Type M4-, M6- or M8- Series single-service activation fitting.

7. **Roof Covering Materials\*** — (Optional, not shown) Consisting of materials compatible with insulations described herein which provide Class A, B or C coverings. See Roofing Materials and Systems Directory - Roof Covering Materials (TEVT).

8. **Insulating Concrete** — (not shown) Optional. Various types of insulating concrete prepared and applied in the thickness indicated:

A. **Vermiculite Concrete** — (not shown) Optional.

1. Blend 6 to 8 cu ft of Vermiculite Aggregate\* to 94 lb Portland Cement and air entraining agent. Min thickness of 2 in. as measured to the top surface of the structural concrete or foamed plastic (Item 9) when it is used.

**SIPLAST INC****VERMICULITE PRODUCTS INC**

2. Blend 3.5 cu ft. of Type NVC Concrete Aggregate\* or Type NVS Vermiculite Aggregate\* to 94 lb Portland Cement. Slurry coat, 1/8 in. thickness beneath foamed plastic (Item 9) when used, 1 in. min topping thickness.

**SIPLAST INC****VERMICULITE PRODUCTS INC**

Vermiculite concrete may be covered with Roof Covering Materials (Item 7).

- B. **Cellular Concrete-Roof Topping Mixture\*** — Concentrate mixed with water and Portland Cement per manufacturers specifications. Min. thickness of 2-in. as measured to the top surface of the structural concrete or foamed plastic (Item 9) when used. 28-day min compressive strength of 190 psi as determined with ASTM C495-66.

**CELCORE INC** — Type Celcore with cast dry density of 31 (+ or - 3.0) pcf or Type Celcore MF with cast dry density of 29 (+ or - 3.0) pcf.

**AERIX INDUSTRIES** —Cast dry density of 37 (+ or -) 3.0 pcf.

**ELASTIZELL CORP OF AMERICA** —Type II. Mix #1 of cast dry density 39 (+ or -) 3.0 pcf, Mix #2 of cast dry density 40 (+ or -) 3.0 pcf, Mix #3 of cast dry density 47 (+ or -) 3.0 pcf.

**LITE-CRETE INC** —Cast dry density of 29 (+ or -) 3.0 pcf.

**SIPLAST INC** —Mix No. 1 or 2. Cast dry density of 32+3 (Mix No. 1) or 36+3 (mix No. 2) pcf.

- C. **Perlite Concrete** — Mix consists of 6.2 cu ft Perlite Aggregate\* to 94 lbs of Portland cement and 1-1/2 pt air entraining agent. Compressive strength 80 psi min.

See Perlite Aggregate (CFFX) category for names of Classified companies.

- D. **Cellular Concrete-Roof Topping Mixture\*** — Foam Concentrate mixed with water, Portland Cement and UL Classified Vermiculite Aggregate per manufacturer's application instructions. Cast dry density of 33 (+ or -) 3.0 pcf and 28-day compressive strength of min 250 psi as determined in accordance with ASTM C495-86.

**AERIX INDUSTRIES** —Mix No. 3.

**SIPLAST INC** —Mix No. 3.

- E. **Floor Topping Mixture\* (Optional, not shown)** — Approx 4.5 gal of water to 41 lbs of NVS Premix floor topping mixture. Slurry coat 1/8 in. thickness beneath foamed plastic (Item 9) when used, 1 in. min topping thickness.

**SIPLAST INC**

Floor Topping Mixture may be covered with Built-Up or Single Membrane Roof Covering.

9. **Foamed Plastic\*** — (Optional-not shown) For use only with vermiculite or cellular concretes or Floor Topping mixture (Item 8E) -Rigid polystyrene foamed plastic insulation having slots and/or holes sandwiched between vermiculite concrete slurry which is applied to the normal or lightweight concrete surface and concrete topping.

**SIPLAST INC****VERMICULITE PRODUCTS INC**

10. **Roof Insulation-Mineral and Fiber Boards\* or Foamed Plastic\*** — (Optional, not shown) — Mineral and fiber boards or polyisocyanurate roof insulation applied over concrete floor with no restriction on board thickness. When mineral and fiber boards or polyisocyanurate roof insulation are used the unrestrained beam rating shall be increased by a min of 1/2 hr. See Mineral and Fiber Boards (CERZ) or Foamed Plastic (CCVW) category for names of Manufacturers.

\*Bearing the UL Classification Mark